



Owner's & Service Manual



Eclipse

Table of Contents

1. Introduction ...	4
2. Safety Information ...	5
3. Technical Specifications ...	11
4. System Descriptions ...	12
4.1 Powertrain System ...	12
4.2 Battery Pack and Management ...	13
4.3 Charging System ...	14
4.4 Drive System (Controller + Motor) ...	15
4.5 Electrical Systems and Wiring ...	16
4.6 Lighting and Signal System ...	19
4.7 Instrumentation and Dashboard Controls ...	22
4.8 Steering & Suspension ...	25
5. Maintenance Schedule ...	26
6. Service Procedures ...	27
6.1 Battery Maintenance ...	27
6.2 Motor Inspection & Replacement ...	28
6.3 Controller Diagnostics ...	29
6.4 Brake Service ...	30
6.5 Suspension & Steering Checks ...	31
6.6 Electrical Troubleshooting ...	32

Table of Contents

7. Wiring Diagrams ...	33
7.1 Main Signal Circuit ...	33
7.2 RND Selector Circuit ...	34
7.3 a Headlight and Turn Signal Circuit A ...	35
7.3 B Headlight and Turn Signal Circuit B ...	36
7.4 Controller Circuit ...	37
8. Torque Specifications ...	38
9. Troubleshooting Guide ...	39
10. Parts & Replacement Guide ...	40
11. Appendices ...	41

1. Introduction

Purpose of Manual:

To provide detailed service, maintenance, and troubleshooting guidance for the EVCO Eclipse Golf Cart.

Vehicle Overview:

The Eclipse is a state-of-the-art electric golf cart built for performance, efficiency, and comfort.

Key Specifications Summary:

Drive Type: Electric Motor

Battery Type: LiFePO₄ (Lithium Iron Phosphate)

Voltage: 48V

Motor Rating: 5kW

Max Speed: 25 mph

Max Range: 90 miles

2. Safety Information

General Workshop Safety:

Use proper tools and lifting techniques. Work in well-ventilated areas and avoid working alone.

Electrical Safety Warnings:

Disconnect the battery before servicing. Use insulated tools and avoid contact with terminals.

Battery Handling Guidelines:

Always wear gloves and eye protection. Prevent short circuits.

Personal Protective Equipment (PPE):

Goggles, gloves, boots, and appropriate clothing.

2. Safety Information

Vehicle Power On/Off and Charging Instructions

Power-On Procedure (When All Power Switches Are Off):

Power On:

- First, press the battery power button to turn on the battery.
- Then, turn the key switch to the ON position.
- This ensures normal operation without triggering any fault alarms or power cycling issues.

Power Off:

- First, turn the key switch OFF.
- Then, press the battery power button to turn it off.

2. Safety Information

Incorrect Power-On Sequence and Fault Recovery:

Incorrect Operation:

- Turning on the key switch first, followed by the battery power button, causes the vehicle to cycle on-off repeatedly.
- The dashboard and display will flash 2–3 times, then the vehicle will shut off automatically.

Fixing the Fault:

- Turn off the key switch, then the battery power button.
- Wait for the vehicle to fully power down, then restart using the correct sequence (battery first, then key).

2. Safety Information

Charging Procedure:

- Turn off the key switch, then the battery power button.
- Insert the charging gun into the charging port.
- The charger will perform an automatic check, and the pre-charge contactor will engage.
- Charging begins normally. When the indicator turns green, unplug the charging gun.

2. Safety Information

Incorrect Charging Procedure and Fault Recovery:

Incorrect Operation:

- Plugging in the charging gun without turning off the key switch and battery power button.
- This bypasses the battery switch, powering the vehicle through the charger.
- The vehicle still charges, but the controller's fault light will blink: 4 green blinks, then 9 red blinks (fault code 4-9: Charging Connection Error).

Fixing the Fault:

- Remove the charging gun.
- Turn off the key switch, then the battery power button.
- Reconnect the charger following the correct procedure.

2. Safety Information

Fault Caused by Powering On While Charging:

- If the key and battery switches are turned ON and before the charging gun is unplugged, the vehicle will cycle power (on-off-on-off), with 2–3 flashes on the dashboard before shutting down.

Fixing the Fault:

- Turn off the key switch, then the battery power button.
- Restart using the correct power-on steps.

Friendly Reminders:

1. Charging Protection:

- While charging, the vehicle's drive motor is disabled to prevent movement.

2. Display During Charging:

- If both switches are ON during charging, the display will function, allowing you to view the SOC (State of Charge) and use display features.
- However, always turn off the power before unplugging the charging gun to avoid power cycling and potential safety hazards.

3. Technical Specifications

- **Dimensions (L x W x H):** 110" x 49" x 73"
- **Ground Clearance:** 7"
- **Vehicle Weight:** 974 lbs
- **Seating Capacity:** 2/4
- **Motor Type:** AC Brushless
- **Controller Type:** FJ ACS1-1
- **Suspension:** Independent Front, Leaf Spring Rear
- **Wheels:** 10" Wheels
- **Brakes (Front/Rear):** Hydraulic Disc
- **Battery Type & Capacity:** 48V 206Ah
LiFePO₄
- **Charging Time & Charger Spec:** 8 hrs, 15A
Smart Charger

4. System Descriptions

4.1 Powertrain System

The EVCO Eclipse powertrain consists of an **AC 3-phase brushless motor** controlled by an **FJ-S1 controller** (model ACS1-1). The controller manages torque output based on signals from the accelerator pedal, brake switch, and speed encoder.

1. **Motor Type:** AC 3-phase
2. **Controller:** FJ-S1 (ACS1-1)
3. **Motor Wiring:** UVW 3-phase outputs from controller
4. **Speed Feedback:** Encoder connected via PHASE A, PHASE B, +5V, and GND
5. **Main Power Control:** Handled via a contactor activated by key switch and +B line
6. **Safety Control:** Emergency stop switch wired inline with contactor circuit
7. **Front Seat Hatch:** Provides access to critical drivetrain components including the battery pack, motor controller, and motor assembly
8. **Service Accessibility:** Designed for quick inspection and replacement of high-voltage system elements without requiring full disassembly

4. System Descriptions

4.2 Battery Pack and Management

The EVCO Eclipse uses a **Ganfeng 48V 206Ah LiFePO₄ (LFP)** lithium-ion battery pack with internal protection features, and supports high-current continuous and pulse discharge.

1. **Model:** GFB 206Ah (PN: EC-AU206-53173200-13FA)
2. **Nominal Voltage:** 3.2V per cell, arranged for ~48V system
3. **Capacity:** 206Ah
4. **Standard Discharge Current:** 0.5C (\approx 103A)
5. **Max Continuous Discharge:** 1.0C (\approx 206A)
6. **Max Pulse Discharge (Long):** 2.0C for 120s
7. **Max Pulse Discharge (Short):** 3.0C for 60s (>40% SOC), 10s (<40% SOC)
8. **Cutoff Voltage:** 2.50V/cell @ 0–60°C, 2.00V/cell @ -20–0°C
9. **BMS Required:** Yes — system requires full BMS control and fault protection

See GFB battery datasheet for full safety and operational constraints.

4. System Descriptions

4.3 Charging System

The Eclipse golf cart features an **onboard charging system** designed for direct connection to a standard wall socket via an external charging cord. The system utilizes a **15A smart charger** capable of monitoring and controlling charge parameters through **CAN communication** with the Battery Management System (BMS).

Key Features:

1. **Type:** Onboard charger (connected via charge port)
2. **Input Source:** Standard GFCI-protected wall outlet (110V–120V AC)
3. **Charging Current:** 15A
4. **Charging Control:** CAN bus interface with BMS
5. **Battery Compatibility:** 48V LiFePO₄ (206Ah)

The BMS enforces safety rules during charging, including cutoff thresholds, temperature monitoring, and charge timeouts as specified in the GFB 206Ah product specification. Charging is terminated if the voltage, temperature, or duration exceeds acceptable parameters.

4. System Descriptions

4.4 Drive System (Controller + Motor)

The Eclipse drive system includes:

1. **Controller:** FJ-S1 Controller (ACS1-1)
2. **Throttle Input:** 0–5V signal via WIPER, LO, POT connections
3. **Motor Phases:** UVW terminals connected to 3-phase AC motor
4. **Speed Sensor:** Encoder connected to controller PHASE A/B inputs
5. **Fault Feedback:** LED blinks indicating fault codes per manufacturer system
6. **CAN Communication:** Connects to BMS and diagnostics tool
7. **Key Protections:** Overvoltage, undervoltage, overtemp, overcurrent, CAN error, sensor faults (see FJ fault doc)

4. System Descriptions

4.5 Electrical Systems & Wiring

The Eclipse golf cart electrical system is powered by a 48V lithium iron phosphate (LiFePO₄) battery pack. A 48V to 12V DC-DC converter is used to supply power to all auxiliary 12V subsystems, including lighting, horn, and dashboard electronics.

Main Power Distribution

- The 48V battery connects through a fused main line to the key switch.
- When activated, the key switch energizes the main contactor, which supplies 48V power to both the motor controller and the DC-DC converter.
- The motor controller (FJ ACS1-1) drives the AC motor through UVW phases based on throttle, brake, and directional input signals.

12V Auxiliary System

- The 48V to 12V DC-DC converter powers all auxiliary circuits.

4. System Descriptions

- Systems on the 12V line include headlights, turn signals, brake lights, horn, and dashboard indicators.
- Each 12V subsystem is protected by a dedicated fuse.

Controller Integration

- Throttle input is received via a 3-wire potentiometer (WIPER, LOW, POT).
- The controller communicates with the Battery Management System (BMS) via a CAN bus.
- Safety features such as overvoltage, undervoltage, overcurrent, and overtemperature protection are integrated into the controller logic.
- System diagnostics are available through LED blink codes and CAN monitoring tools.

4. System Descriptions

Reference Diagrams

Wiring architecture and signal routing are detailed in the following diagrams:

Main Signal Circuit – Page 26

RND Selector Circuit – Page 27

Headlight and Turn Signal Circuit – Pages 28 & 29

Controller Circuit – Page 30

This structure ensures functional separation between high-voltage propulsion components and low-voltage auxiliary systems, supporting safe and efficient operation.

4. System Descriptions

4.6 Lighting & Signal System

The Eclipse golf cart includes a complete 12V lighting and signal system powered by the onboard DC-DC converter. The system supports standard road visibility and signaling functions and is protected via a dedicated fuse panel.

Components

1. **Headlights:** Forward-facing illumination, activated via a dashboard-mounted switch.
2. **Tail Lights:** Rear illumination for visibility during low-light conditions.
3. **Turn Signals:** Left and right indicators operated by a manual stalk or switch.
4. **Brake Lights:** Activated by the brake pedal switch, providing rear signaling during deceleration.
5. **Horn:** Activated via a momentary contact button on the dashboard or steering column.

4. System Descriptions

Electrical Characteristics

1. **Operating Voltage:** 12V DC (supplied by DC-DC converter)
2. **Protection:** Each circuit is fused individually via a dedicated fuse panel located below the dash, accessible through the service panel.

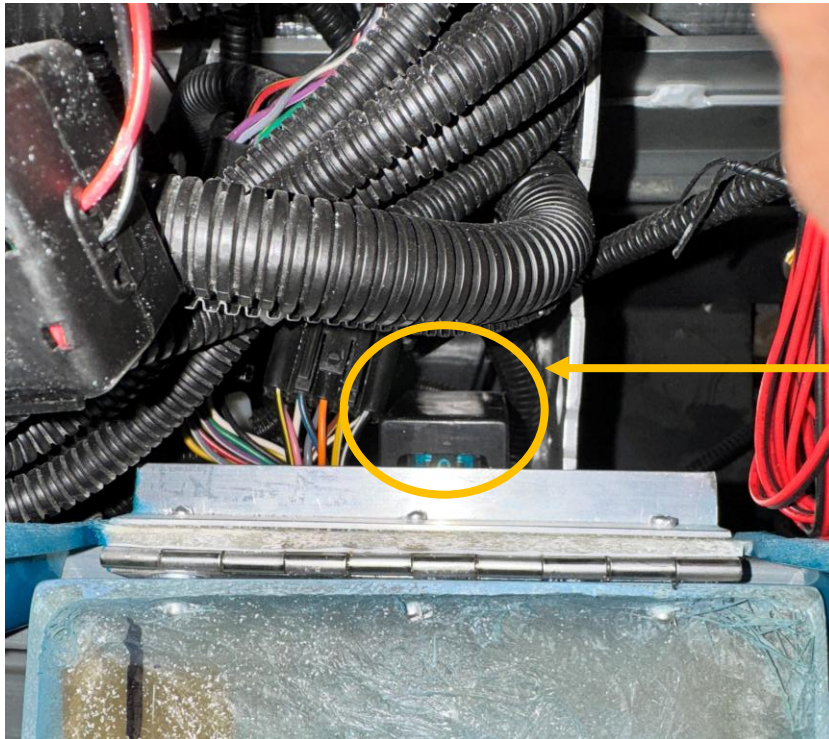

Fuse
Box

4. System Descriptions

With reference to the diagram on Page 33, the functions of fuses are as described below:

- Fuse 59: Multi-switches (Hi/Lo Beam selector)
- Fuse 52: Turn Signals
- Fuse 81: Headlights, Tail Lights and Dome Lights
- Fuse 23: Drive, Neutral and Reverse Selector
- Fuse 62: Ignition Switch
- Fuse 30: USB, 12V Cigarette Lighter and Radio
- Fuse 51: DC-DC Converter

3. Control Method: Mechanical relays are used to switch high-current lighting loads

4. System Descriptions

4.7 Instrumentation & Dashboard Controls

The Eclipse dashboard consolidates essential driver controls, status indicators, and utility features in a centrally located panel.

Electrical Interfaces

1. **Throttle Input:** Wired via a 3-pin potentiometer (WIPER, LOW, POT)
2. **Key Switch:** Activates the main contactor and controller
3. **CAN Interface:** Available for PC-based configuration and diagnostics
4. **Diagnostic Port:** Includes CAN_H, CAN_L, and CAN_TERM lines for BMS and controller access

4. System Descriptions

Dashboard Components:

1. **Key Switch:** Main system activation
2. **Speedometer:** Displays vehicle speed and integrated battery status
3. **Stereo System:** Integrated audio entertainment unit
4. **USB Ports:** For device charging
5. **Cigarette Lighter Outlet:** 12V auxiliary output
6. **R-N-D Selector Dial:** For choosing forward, reverse, or neutral
7. **Battery Power Button:** Push-button control for turning the battery system on or off
8. **Front Hood Release Button:** Electrically actuated release mechanism
9. **High/Low Beam Selector:** Located to the left of the driver
10. **Rearview Mirror Display:** Integrated screen for backup camera feed
11. **Backup Camera:** Mounted at the rear; automatically activates in reverse

4. System Descriptions

- 12. Utility Features:** Four integrated cup holders for passenger convenience
- 13. Access Panel:** Located below the dashboard; provides direct access to electrical distribution and wiring for diagnostics and repair

The layout allows clear access to all critical vehicle functions and supports user-friendly operation in both personal and commercial environments.

4. System Descriptions

4.8 Steering & Suspension

The Eclipse uses a combination of precision steering and dual-architecture suspension for balanced handling and comfort.

Steering System

1. **Type:** Rack and pinion
2. **Actuation:** Manual
3. **Mounting:** Chassis-mounted steering column connected via steering shaft to front wheel assembly
4. **Suspension System**
5. **Front Suspension:** Independent setup for improved control and reduced vibration on uneven terrain
6. **Rear Suspension:** Leaf spring arrangement, providing durability and load-carrying capacity

This configuration is optimized for low-speed maneuverability and stability under variable passenger and cargo loads.

5. Maintenance Schedule

Mileage	Component	Task	Notes
Every 250 mi	Tires	Inspect pressure and tread depth	Inflate to spec; rotate if needed
	Battery	Inspect terminals and harness connections	Clean corrosion and tighten connections
	Brake System	Check fluid level and pedal response	Top off with DOT-approved fluid
	Lighting & Horn	Test for full functionality	Replace bulbs or fuses as needed
Every 500 mi	Electrical System	Visually inspect wiring and fuse panel	Inspect under-dash access panel
Every 1000 mi	Battery Pack	Perform voltage and SOC diagnostics	Use CAN-enabled BMS tools
	Brake Pads	Inspect pad thickness and rotor surface	Replace below 3 mm thickness
	Frame & Chassis	Inspect for rust and integrity	Focus on under-seat and floorpan areas
Every 5000 mi	Full System Review	Comprehensive inspection of all systems	Document condition of all key systems
	Tire Replacement	Assess tread wear or cracking	Replace if worn or aged
	Steering System	Inspect for play or looseness	Check rack mounts and tie rods
	Suspension	Inspect front and rear components	Look for wear or damage
	Frame & Chassis	Inspect for rust and integrity	Focus on under-seat and floorpan areas
	Motor	Clean housing and inspect mounts	Confirm UVW connections
	Controller	Update firmware (if applicable)	Use FJ software
	DC-DC Converter	Confirm stable 12V output	Replace if voltage drops or fluctuates

6. Service Procedures

6.1 Battery Maintenance

Tools Needed: Multimeter, insulated wrench, corrosion cleaner

Procedure:

1. Turn off battery using dashboard button
2. Disconnect negative terminal first
3. Inspect terminals for corrosion or loose connections
4. Clean as needed; torque to manufacturer spec
5. Reconnect terminals and restore power

Caution: Never short battery terminals. Always wear eye and hand protection.

6. Service Procedures

6.2 Motor Inspection & Replacement

Tools Needed: Torque wrench, socket set, lifting aid

Procedure:

1. Open front seat hatch
2. Disconnect motor phase (UVW) cables and encoder lines
3. Unbolt motor from chassis mount
4. Replace or inspect motor; reverse steps to reinstall

Caution: Support the motor during removal to prevent strain on wiring.

6. Service Procedures

6.3 Controller Diagnostics

Tools Needed: Laptop with FJ software, CAN cable

Procedure:

1. Connect to diagnostic port under dash (CAN_H, CAN_L, CAN_TERM)
2. Power on the system
3. Launch diagnostics tool and check for fault codes
4. Refer to FJ ACS1-1 fault code list for solutions

Caution: Ensure correct CAN termination before initiating diagnostics.

6. Service Procedures

6.4 Brake Service

Tools Needed: Brake fluid, socket set, caliper tool

Procedure:

1. Jack up vehicle and remove wheels
2. Inspect pad wear and rotor surface
3. Refill brake fluid reservoir as needed
4. Bleed brake lines if air is present

Caution: Use only the recommended brake fluid (DOT3 or DOT4). Avoid contamination.

6. Service Procedures

6.5 Suspension and Steering Checks

Tools Needed: Torque wrench, jack stands, inspection light

Procedure:

1. Inspect front independent suspension arms and joints
2. Check rear leaf spring shackles and U-bolts
3. Inspect rack and pinion for free play. (Acceptable steering free play: no more than **15–20 mm (0.6–0.8 inches)** measured at the steering wheel rim with front wheels in the straight-ahead position)

Caution: Perform checks with the cart securely supported on flat ground.

6. Service Procedures

6.6 Electrical Troubleshooting

Tools Needed: Multimeter, wiring diagram

Procedure:

1. Refer to wiring schematics
2. Test continuity, fuse conditions, and voltage at DC-DC output
3. Isolate and replace any damaged connectors or wires

Caution: Disconnect the battery before working on any electrical component.

7. Wiring Diagrams

7.2 RND Selector Circuit

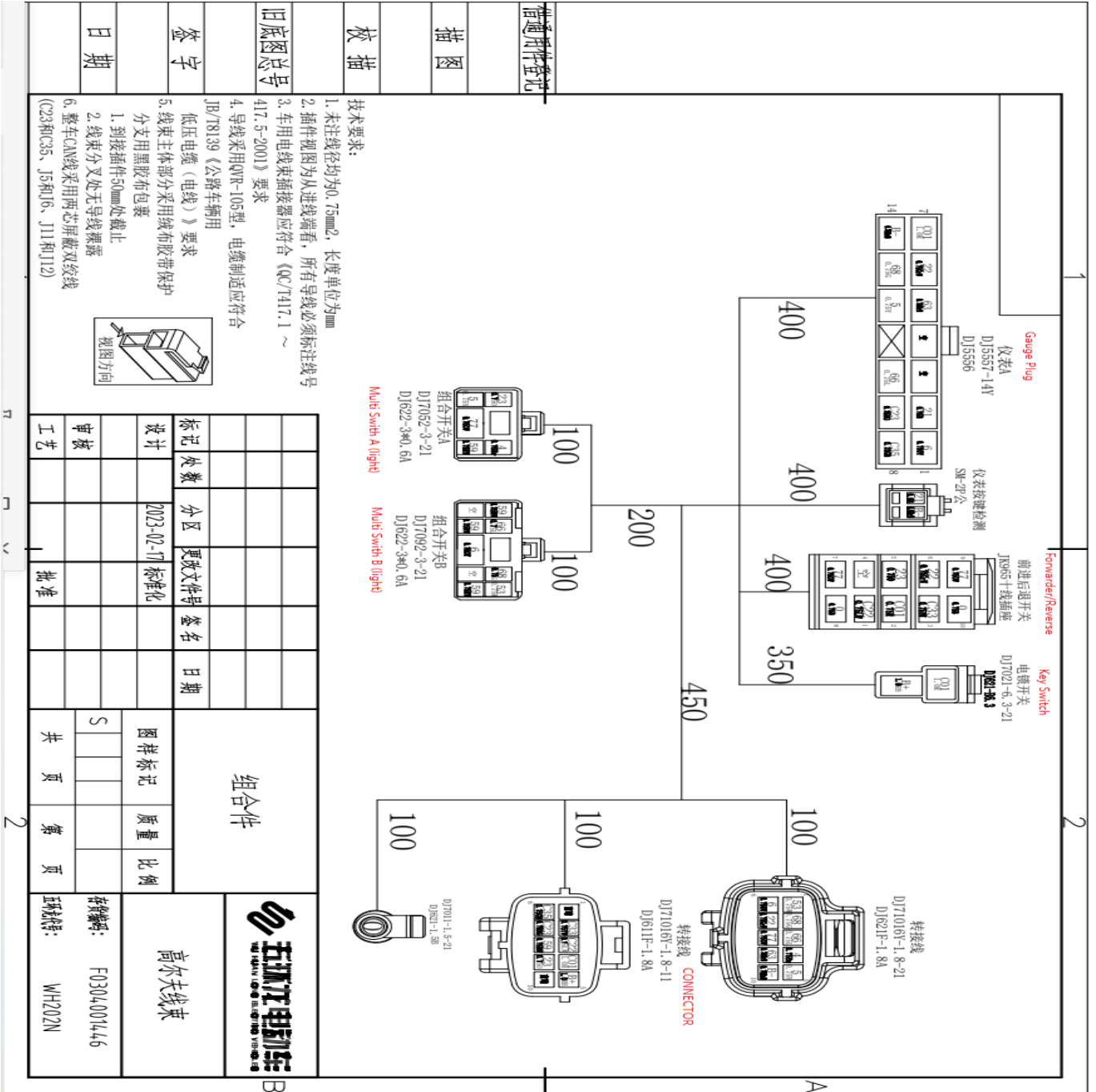

7. Wiring Diagrams

7.3 a. Headlight and Turn Signal Circuit

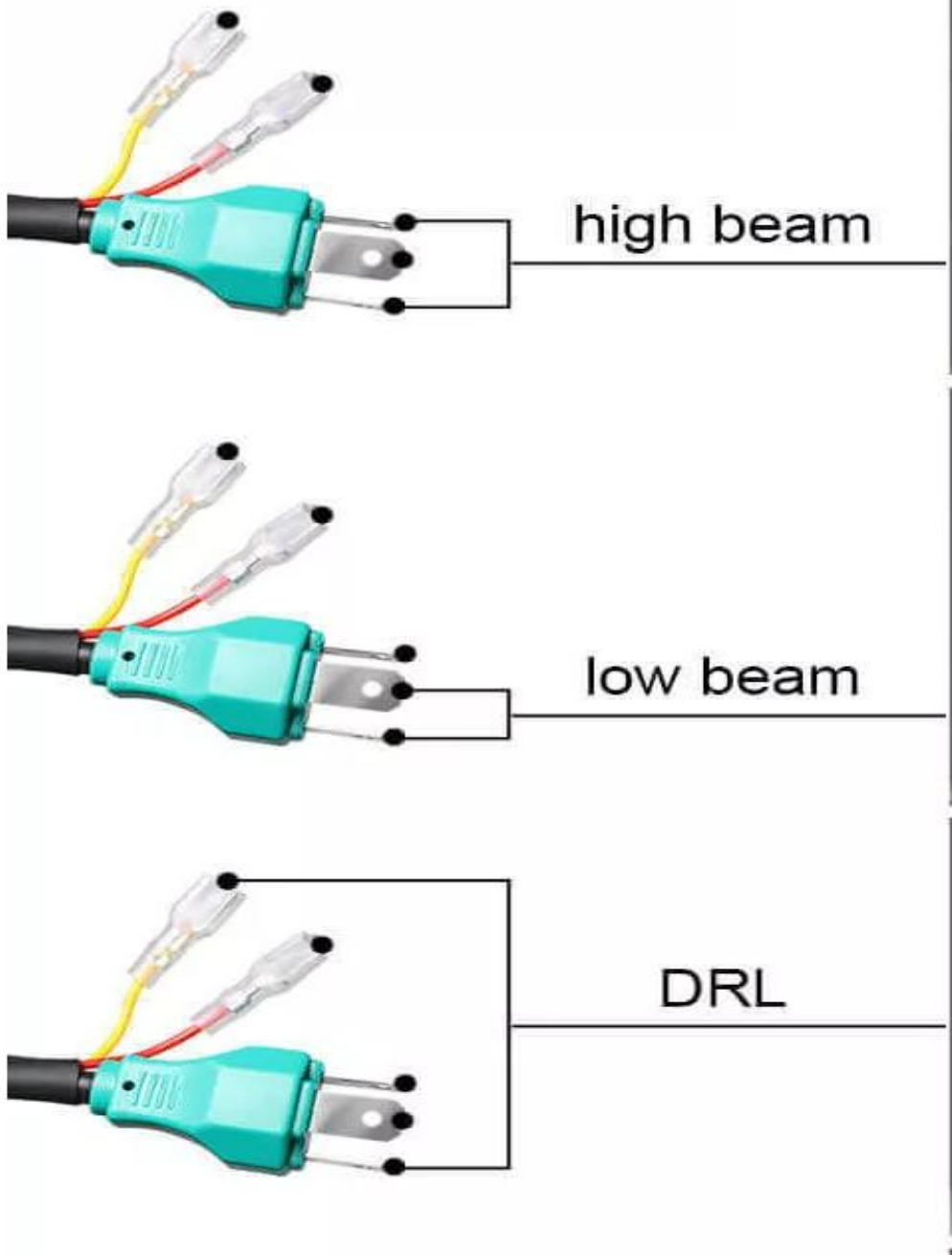

7. Wiring Diagrams

7.3 b Headlight and Turn Signal Circuit

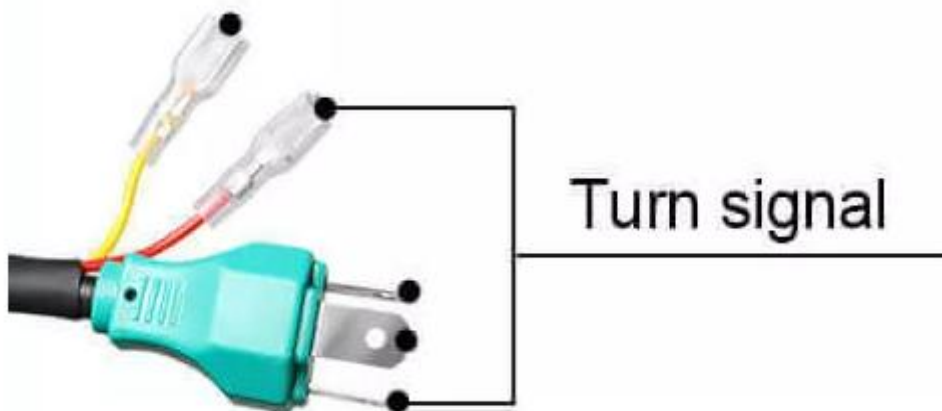
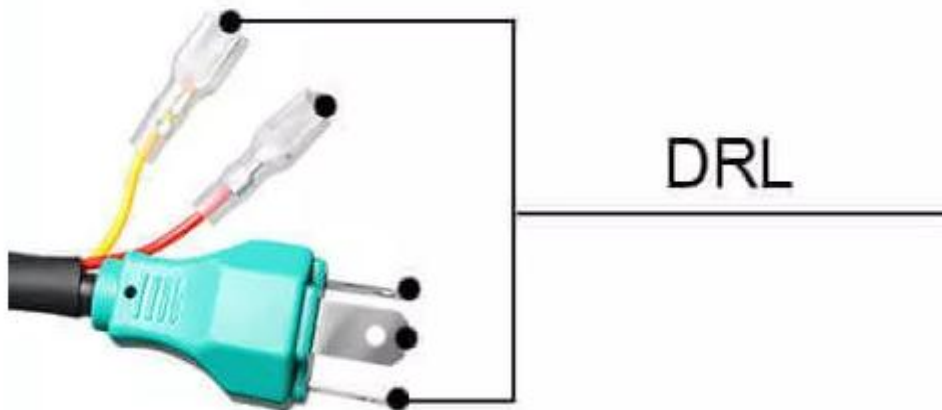

7. Wiring Diagrams

7.4 Controller Circuit

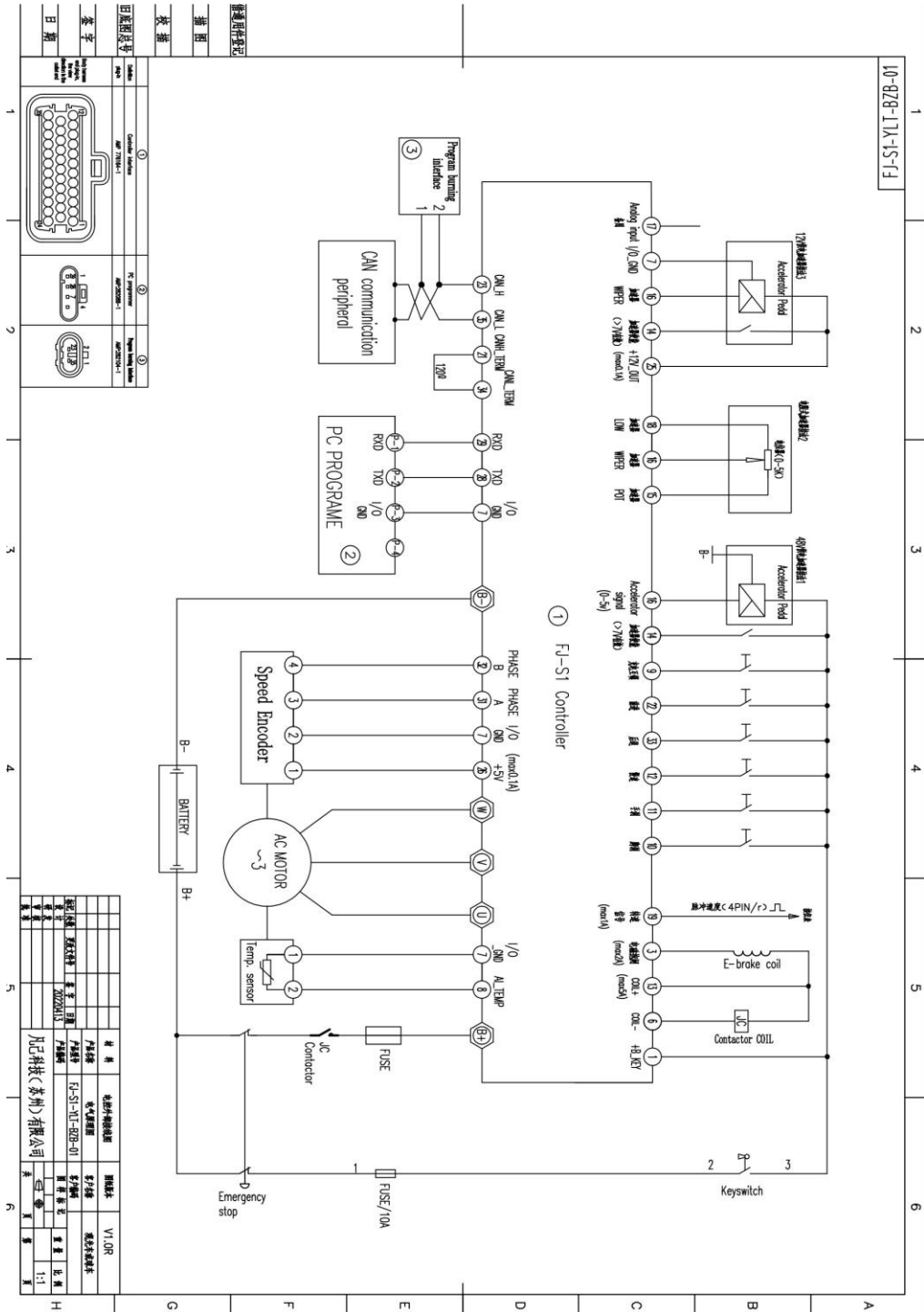

8. Torque Specifications

Component	Torque Specs
Lug Nuts	90-100 Nm
Battery Terminals	8-10 Nm
Motor Mount Bolts	45-50 Nm
Leaf Spring U Bolts	70-75 Nm
Steering Rack Bolts	35-40 Nm

9. Troubleshooting Guide

1. **No Power:** Check battery switch and main fuse → Replace fuse or restore power
2. **Jerky Acceleration:** Read fault codes via LED Light on controller → Resolve per ACS1-1 fault table
3. **Brake Lights Not Working:** Check fuse and pedal switch → Replace if needed
4. **Headlights Inoperative:** Test 12V circuit, relays → Replace relay or bulb
5. **No Drive/Reverse:** Check R-N-D switch continuity → Replace selector if faulty
6. **Backup Camera Dead:** Inspect mirror wiring → Reseat or replace camera module

10. Parts and Replacement Guide

1. Battery Pack: GFL02062
2. Controller: FJ ACS1-1
3. Rear View Mirror: 32000
4. Taillights: 76385
5. Lighting Relay: R5-SPDT-1240
6. Radio and Antenna: MET 44-UA20

11. Appendices

11.1 Glossary

- BMS – Battery Management System
- DC-DC Converter – Converts 48V to 12V
- CAN Bus – Digital controller communication protocol
- FJ ACS1-1 – Eclipse motor controller model
- SOC: State of Charge- Percentage indicator of remaining battery capacity

11.2 Contact Information

EVCO Manufacturing

405 N Grandview St

Union City, OH 45390

+1 (937) 741-3332